

Case Unit SMA_LUU

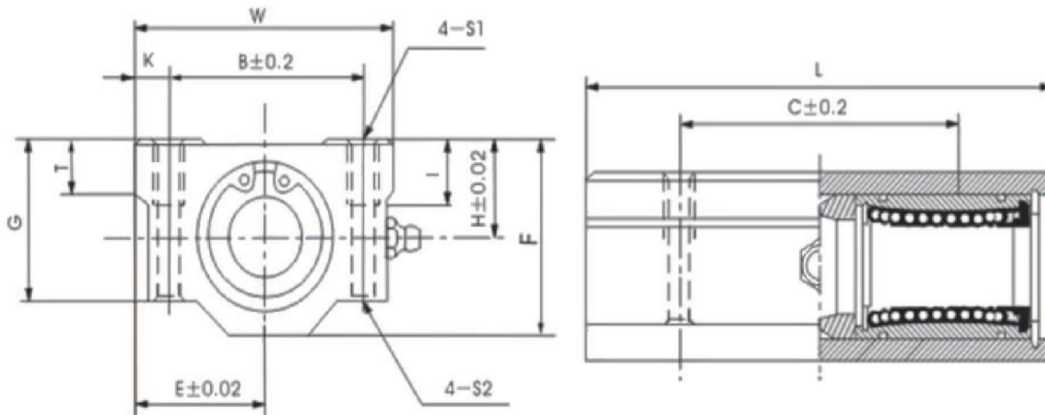
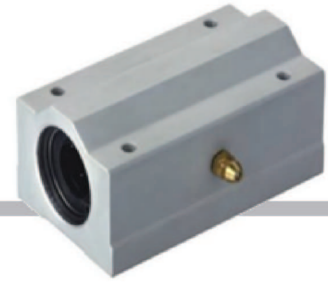

MODEL	SHAFT DIAMETER	MAIN DIMENSIONS							MOUNTING DIMENSIONS						WEIGHT [Kg]
		H	E	W	L	F	G	T	B	C	K	S1	S2	I	
SMA8LUU	8	11	17	34	58	22	18	6	24	42	5	M4	3.4	8	0.1
SMA10LUU	10	13	20	40	68	26	21	8	28	46	6	M5	4.3	12	0.18
SMA12LUU	12	15	21	42	70	28	24	8	30.5	50	5.75	M5	4.3	12	0.2
SMA13LUU	13	15	22	44	75	30	24.5	8	33	50	5.5	M5	4.3	12	0.23
SMA16LUU	16	19	25	50	85	38.5	32.5	9	36	60	7	M5	4.3	12	0.39
SMA20LUU	20	21	27	54	96	41	35	11	40	70	7	M6	5.2	12	0.49
SMA25LUU	25	26	38	76	130	51.5	42	12	54	100	11	M8	7	18	1.165
SMA30LUU	30	30	39	78	140	59.5	49	15	58	110	10	M8	7	18	1.43
SMA35LUU	35	34	45	90	155	68	54	18	70	120	10	M8	7	18	2.13
SMA40LUU	40	40	51	102	175	78	62	20	80	140	11	M10	8.7	25	3.09
SMA50LUU	50	52	61	122	215	102	80	25	100	160	11	M10	8.7	25	6.53